

**thermaline S90 BAIN MARIE, ELEKTRISCH
BAIN MARIE, ELECTRIC
BAGNOMARIA, ELETTRICHE
BAIN-MARIE, ÉLECTRIQUE**

MODEL CODE / PNC
freistehend, free standing , isolato, isolé einseitig bedienbar, operated from one side, comando da un lato, utilisable d'un côté
ABARAOOOO / 582290 ABARHAOOO / 582291 ABARBAOOO / 599610 ABATAAOOO / 582300 ABATHAOOO / 582301 ABATBAOOO / 582306
freistehend, free standing , isolato, isolé beidseitig bedienbar, operated from both sides, comando da due lati, utilisable des deux côtés
ABARACOOO / 582294 ABARHCOOO / 582295 ABARBCOOO / 582298 ABATACOOO / 582304 ABATHCOOO / 582305 ABATBCOOO / 582310
an Wand, against wall, contro la parete, contre cloison,
ABARAFOOO / 582292 ABARHFOOO / 582293 ABARBFOOO / 599609 ABATAFOOO / 582302 ABATHFOOO / 582303 ABATBFOOO / 582308 ABAROI000 / 582517 ABATOIOOO / 582518

**DE ERSATZTEILLISTE
GB SPARE PARTS LIST
IT LISTA DEI PEZZI DI RICAMBIO
FR LISTE DES PIÈCES DE RECHANGE**

doc.	62.9587.02
edition	2
dat.	01.2004

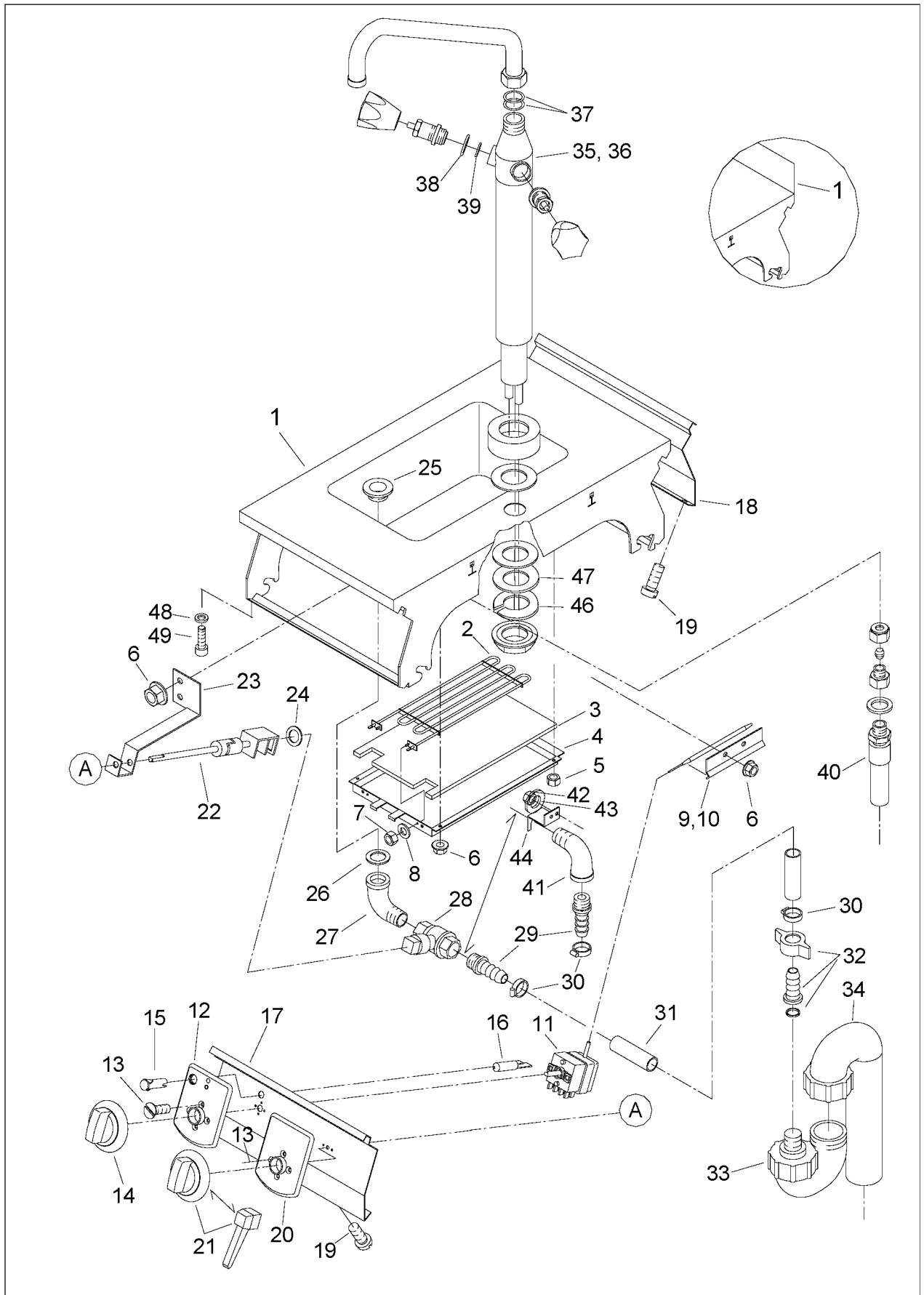

**thermaline S90 BAIN MARIE, ELEKTRISCH
BAIN MARIE, ELECTRIC
BAGNOMARIA, ELETTRICHE
BAIN-MARIE, ÉLECTRIQUE**

MODEL CODE / PNC	
freistehend, free standing , isolato, isolé einseitig bedienbar, operated from one side, comando da un lato, utilisable d'un côté	
ABARAAOOOO / 582290	
ABARHAOOOO / 582291	
ABARBAOOOO / 599610	
ABATAAOOOO / 582300	
ABATHAOOOO / 582301	
ABATBAOOOO / 582306	
freistehend, free standing , isolato, isolé beidseitig bedienbar, operated from both sides, comando da due lati, utilisable des deux côtés	
ABARACOOOO / 582294	
ABARHCOOOO / 582295	
ABARBCOOOO / 582298	
ABATACOOOO / 582304	
ABATHCOOOO / 582305	
ABATBCOOOO / 582310	
an Wand, against wall, contro la parete, contre cloison,	
ABARAFOOOO / 582292	
ABARHFOOOO / 582293	
ABARBFOOOO / 599609	
ABATAFOOOO / 582302	
ABATHFOOOO / 582303	
ABATBFOOOO / 582308	
ABAROIIOOOO / 582517	
ABATOIOOOO / 582518	

**DE ERSATZTEILLISTE
GB SPARE PARTS LIST
IT LISTA DEI PEZZI DI RICAMBIO
FR LISTE DES PIÈCES DE RECHANGE**

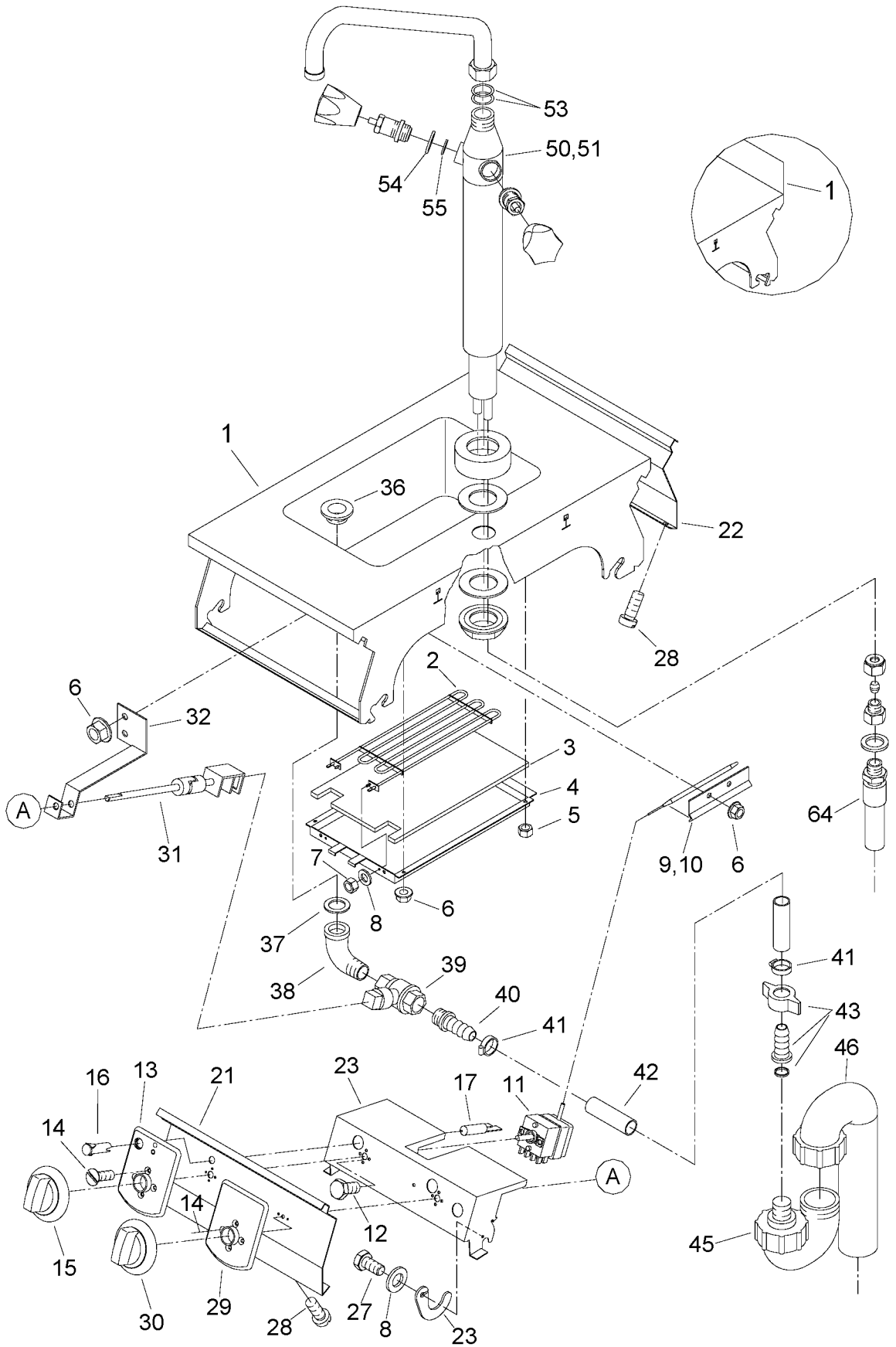

62.9587.02-1		DE	GB	IT	FR	E		W	
		Bezeichnung	designation	designazione	désignation	500	700	500	700
		Bain Marie GN	Bain Marie GN	Bagnomaria GN	Bain Marie GN	1/1	2/1	1/1	2/1
Pos.	Product No.	Oberteil	top	parte superiore	partie supérieure				
1	62.3676	Oberteil	top	parte superiore	partie supérieure	1			
	62.3673	Oberteil	top	parte superiore	partie supérieure			1	
	62.4135.01	Oberteil	top	parte superiore	partie supérieure		1		
	62.4135.02	Oberteil	top	parte superiore	partie supérieure				1
2	1 115 1591	Heizung 200V	heating 200V	riscaldamento 200V	chauffage 200V	1	2	1	2
	1 115 1583	Heizung 400V	heating 400V	riscaldamento 400V	chauffage 400V	1	2	1	2
3	1 201 2056	Isolation	isolation	isolamento	insulation	1	2	1	2
4	62.3687	Gehäuse	housing	base	boîtier	1		1	
	62.4138	Gehäuse	housing	base	boîtier		1		1
5	1 701 3008	Mutter M5	nut M5	dado M5	écrou M5	2		2	
6	712 044120.05	Kepsmutter	capitre nut	dado	écrou	6	6	6	6
7	1 701 3004	Mutter M4	nut M4	dado M4	écrou M4	2	4	2	4
8	1 701 7060	Fächerscheibe M4	serrated lock washer M4	rondella serrante M4	rondelle de serrage M4	4	4	4	4
9	72.1096	Fühlerhalter	sensor support	sostegno del sensore	support de sonde	1	1	1	1
10	72.1278	Fühlerisolation	sensor isolation	isolamento del sensore	insulation de sonde	1	1	1	1
11	1 115 1590	Regler	regulator	regolatore	régulateur	1	1	1	1
12	1 701 2019	Schraube	screw	vite	vis	2	2	2	2
13	62.3577	Grundplatte	base plate	lamiera di fondo	tôle de base	1		1	
13	62.4083	Grundplatte	base plate	lamiera di fondo	tôle de base		1		1
14	1 701 1006	Senkschraube	flat head screw	vite	vis à tête fraisée	4	4	4	4
15	62.3649	Griff	knob	manetta	poignée	1	1	1	1
16	72.5938.08	Fassung	socket	disposizione	monture	1	1	1	1
17	72.5938.04	Glimmlampe	glowing lamp	lampada	lampe fluorescente	1	1	1	1
21	62.3522	Blende	filler	copertura	bandeau	1		1	
	62.4144	Blende	filler	copertura	bandeau		1		1
22	62.3513.01	Blende	filler	copertura	bandeau	1		1	
	62.4000	Blende	filler	copertura	bandeau		1		1
23	62.3630	Schalterbefestigung	switch fixation plate	fissaggio d'interruttore	fixation pour interrupteur	1		1	
	62.4145	Schalterbefestigung	switch fixation plate	fissaggio d'interruttore	fixation pour interrupteur		1		1
23		Lasche	latch	coprigiunto	languette	2		2	
27	1 701 2503	Schraube M4x8	screw M4x8	vite M4x8	vis M4x8	2	2	2	2
28	10.3179	Schraube	screw	vite	vis	4	4	4	4

62.9587.02-1		DE	GB	IT	FR	E		W	
		Bezeichnung	designation	designazione	désignation	500	700	500	700
		Bain Marie GN	Bain Marie GN	Bagnomaria GN	Bain Marie GN	1/1	2/1	1/1	2/1
Pos.	Product No.	Oberteil	top	parte superiore	partie supérieure				
29	62.3645	Grundplatte	base plate	lamiera di fondo	tôle de base	1		1	
30	62.3654	Griff	knob	manetta	poignée	1		1	
	72.3461	Hebel	lever	leva	levier		1		1
31	62.3653	Gestänge	linkage	raccordo	raccordement	1		1	
	62.4182	Gestänge	linkage	raccordo	raccordement		1		1
32	62.3689	Halter	support	sostegno	fixation	1		1	
33	1 701 5 051	Fächerscheibe M6	serrated lock washer M6				1		1
36	1 102 2423	Nippel G1/2	nipple G1/2	raccordo G1/2	mamelon G1/2	1		1	
	1 102 2425	Nippel G3/4	nipple G3/4	raccordo G3/4	mamelon G3/4		1		1
37	1 101 2161	Dichtung	sealing	guarnizione	joint	1		1	
	712 044 481.09	Dichtung G3/4	sealing G3/4	guarnizione G3/4	joint G3/4		1		1
38	1 101 2162	Winkel 1/2	angle 1/2	angolo 1/2	angle 1/2	1		1	
	1 201 2009	Winkel 3/4	angle 3/4	angolo 3/4	angle 3/4		1		1
39	1 117 1255	Kugelhahn 1/2"	ball valve 1/2"	valvola sferica 1/2"	robinet à boisseau 1/2"	1		1	
	1 117 1256	Kugelhahn 3/4"	ball valve 3/4"	valvola sferica 3/4"	robinet à boisseau 3/4"		1		1
40	1 701 2741	Stutzen	flange	carabina	manchon	1		1	
	1 701 2756	Stutzen 3/4x16	flange 3/4x16	carabina 3/4x16	manchon 3/4x16		1		1
41	12.9827	Bride	shackle	brida	bride	2	2	2	2
42	1 701 2742	Schlauch	hose	tubo flessibile	tuyau flexible	1	1	1	1
43	1 701 2740	Verschraubung	screwing	collegamento	vissage	1	1	1	1
45	1 102 2010	Stutzen	flange	carabina	manchon	1	1	1	1
46	1 105 1210	Siphon	siphon	sifone	siphon	1	1	1	1
50	1 105 1257	Mischbatterie h=465	mixer unit h=465	batteria erogazione acqua h=465	mitigeur h=465	1	1	1	1
51	1 105 1255	Mischbatterie h=655	mixer unit h=655	batteria erogazione acqua h=655	mitigeur h=655	1	1	1	1
53	1 201 2061	Dichtung	sealing	guarnizione	joint	2	2	2	2
54	1 201 2062	Dichtung	sealing	guarnizione	joint	2	2	2	2
55	1 201 2063	Dichtung	sealing	guarnizione	joint	2	2	2	2
64	712 344 893.02	Schlauch	hose	tubo flessibile	tuyau flexible	2		2	
	712 344 893.01	Schlauch	hose	tubo flessibile	tuyau flexible		2		2
56	1 701 2755	Winkel 3/4	angle 3/4	angolo 3/4	angle 3/4		1		1
57	1 701 2507	Schraube M5x8	screw M5x8	vite M5x8	vis M5x8		2		2
58	1 701 7002	Fächerscheibe M5	serrated lock washer M5	rondella serrante M5	rondelle de serrage M5		2		2

62.9587.02-1		DE	GB	IT	FR	E		W	
		Bezeichnung	designation	designazione	désignation	500	700	500	700
		Bain Marie GN	Bain Marie GN	Bagnomaria GN	Bain Marie GN	1/1	2/1	1/1	2/1
Pos.	Product No.	Oberteil	top	parte superiore	partie supérieure				
59	62.4207	Halter	support	sostegno	fixation		1		1
E		einseitig bedienbar	operated from one side	comando da un lato	utilisable d'un côté				
W		an Wand stehend	against wall	contro la parete	contre cloison				